

DS2 Disinfectant Sprayer

Model: C46200-00DS



TECHNICAL SPECIFICATIONS

Model: DS2 Disinfectant Sprayer

Model No.: C46200-00DS

Solution/Recovery Tank Capacity	1.3 gallons (5 ltr)
Voltage	115 volts
Solution Pump.	100 PSI
Power Cord	25 feet (7.6m)
Construction.	Rotationally Molded Polyethylene
Dimensions (L:xWxH)	19" x 8.75" x 17" (48cm x 22 cm x 43 cm)
Weight	19 lbs (8.16 kg)
Wheel Diameter	(2) - 4" (10 cm)

Specifications are subject to change without notice.

For Safety When Servicing or Maintaining Machine

- Stop on level surface.
- Unplug machine from power source before any service or maintenance is to be performed.
- Avoid moving parts. Do not wear loose jackets, shirts, or sleeves when working on machine.
- Do not clean machine with a pressure washer.
- Authorized personnel must perform repairs and maintenance. Use Minuteman supplied replacement parts.

Table of Contents

Inspection.....	6
Electrical - Model C46200-00DS (115V).....	6
Grounding Instructions.....	6
User Maintenance Instructions	7
Daily Maintenance	7
Monthly/Bi-Monthly Maintenance.....	7
Cord Storage	7
Operating Instructions	8
Frame Assembly (450200DS).....	10
Base Assembly	12
Handle Assembly (450413).....	14
Wand Assembly (450250DS).....	16
Option - Extension Wand (450311).....	18
Wiring.....	20

FOR COMMERCIAL USE ONLY

IMPORTANT SAFETY INSTRUCTIONS

When using an electrical appliance, basic precautions should always be followed, including the following:

READ ALL INSTRUCTIONS BEFORE USING

WARNING – To reduce the risk of fire, electric shock or injury:

Do not leave appliance when plugged in. Unplug from outlet when not in use and before servicing.

WARNING

To reduce the risk of electrical shock, do not expose to rain. Store indoors.

- Do not allow to be used as a toy. Close attention is necessary when used by or near children.
- Use only as described in this manual. Use only manufacturer's recommended attachments.
- Do not use with damaged cord or plug. If appliance is not working as it should, has been dropped, damaged, left outdoors, or dropped into water, return it to a service center.
- Do not pull or carry by cord, use cord as a handle, close a door on cord, or pull cord around sharp edges or corners. Do not run appliance over cord. Keep cord away from heated surfaces.
- Do not unplug by pulling on cord. To unplug, grasp the plug, not the cord.
- Do not handle plug or appliance with wet hands.
- Do not put any object(s) into opening. Do not use with any of the openings blocked. Keep free of dust, lint, hair, and anything else that may reduce solution flow.
- Keep hair, loose clothing, fingers, and all parts of body away from openings and moving parts.
- Do not spray on anything that is burning or smoking, such as cigarettes, matches, or hot ashes.
- Turn off all controls before unplugging.
- Do not use to spray on or by flammable or combustible liquids such as gasoline, or use in areas where they may be present.
- Connect to a properly grounded outlet only. See grounding instructions.

SAVE THESE INSTRUCTIONS

Inspection

Carefully unpack and inspect your machine for shipping damage. Each unit is tested and thoroughly inspected before shipment, and any damage is the responsibility of the delivery carrier who should be notified immediately.

Electrical - Model C46200-00DS (115V)

This machine is designed to operate on a standard 15 amp, 115 volt, 60 hz, AC circuit. Voltages below 105 volts AC or above 125 volts AC could cause serious damage to the motor.

WARNING - Electric motors can cause explosions when operated near explosive materials or vapors. Do not operate this machine near flammable materials such as solvents, thinners, fuels, grain dust, etc.

Grounding Instructions

This appliance must be grounded. If it should malfunction or breakdown, grounding provides a path of least resistance for electric current to reduce the risk of electric shock. This appliance is equipped with a cord having an equipment-grounding conductor and grounding plug. The plug must be plugged into an appropriate outlet that is properly installed and grounded in accordance with all local codes and ordinances.

DANGER - Improper connection of the equipment-grounding conductor can result in a risk of electric shock. Check with a qualified electrician or service person if you are in doubt as to whether the outlet is properly grounded. Do not modify the plug provided with the appliance -- if it will not fit the outlet, have a proper outlet installed by a qualified electrician.

This appliance is for use on a nominal 120-volt circuit and has a grounding plug that looks like the plug illustrated in sketch A below. Make sure that the appliance is connected to an outlet having the same configuration as the plug. No adapter should be used with this appliance.

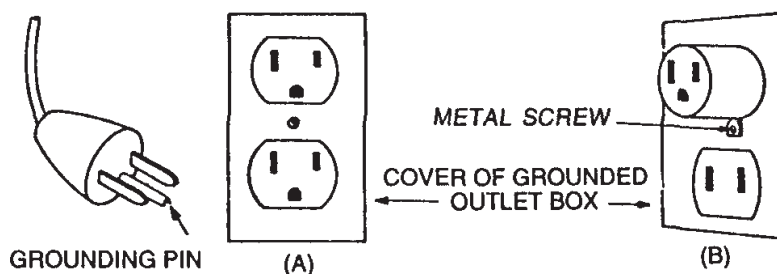

User Maintenance Instructions

All service and repair should be performed by qualified service representative or electrician.

Daily Maintenance

1. Solution tank should be emptied after each use. Flush pumping system with 1 gallon of clean water after use.
2. Removal of nozzle tip, cap, gasket cap, and check valve can expedite system flush to allow full water flow from the pump. See Wand Assembly (pg. 16-17) for details. After system flush, de-pressurize system by removing power from machine and keeping the spray wand in the on-position until the flow has stopped. Reassemble spray wand head afterwards as necessary.
3. Spray jet should be checked for correct spray pattern and cleaned if plugged. Do not clean out spray tip with pins or wire, this may cause damage to the jet spray pattern and cause streaking.
4. Protect equipment from freezing. Severe pumping system damage can occur if allowed to freeze.
5. Inspect hoses for tight connections. Check electrical cable for abrasion or cuts in jacket. Cord should be replaced if worn or damaged.

Monthly/Bi-Monthly Maintenance

The Solution Pump System should be purged monthly to remove residue build-up. To flush system out, use 1 quart of white vinegar to 1 1/2 gallons of clean hot water, followed by a clear 1 1/2 gallon rinse. Clean spray jets if required.

Cord Storage

While not in use storage can be accomplished by winding cord around top of machine. Cord hooks are provided.

- Do not use with damaged cord or plug. If appliance is not working as it should, has been dropped, damaged, left outdoors, or dropped into water, return to service center.
- Do not pull or carry by cord, use cord as handle, close a door on cord, or pull cord around sharp edges or corners. Do not run appliance over cord. Keep cord away from heated surfaces.
- Do not unplug by pulling cord. To unplug, grasp the plug, not the cord.
- Do not handle plug or appliance with wet hands.

This equipment should be stored indoors and not exposed to rain.

Operating Instructions

1. Lift the cover tank off of the of solution tank by releasing the two latches.
2. Add up to 1-1/2 gallons of disinfectant solution to the solution tank. Use only commercially available cleaning chemicals.
3. Place the cover tank back on solution tank and fasten the two latches.
4. Plug power cord into grounded wall outlet.
5. Connect the solution hose assembly to machine.
6. Turn on machine via the rocker switch on the back of the machine. Purge air from the lines by operating the wand in an upward angle for a few seconds.
7. Machine will run as necessary to keep the pressure and can be used without power for a certain amount of time as long as there is pressure built up in the system.
8. Warning: Do not overfill. Shutdown machine by switching the rocker switch to the off position and unplugging from the power source. De-pressurize the system by holding the spray wand in the on position until no more solution is sprayed while the machine is not powered.

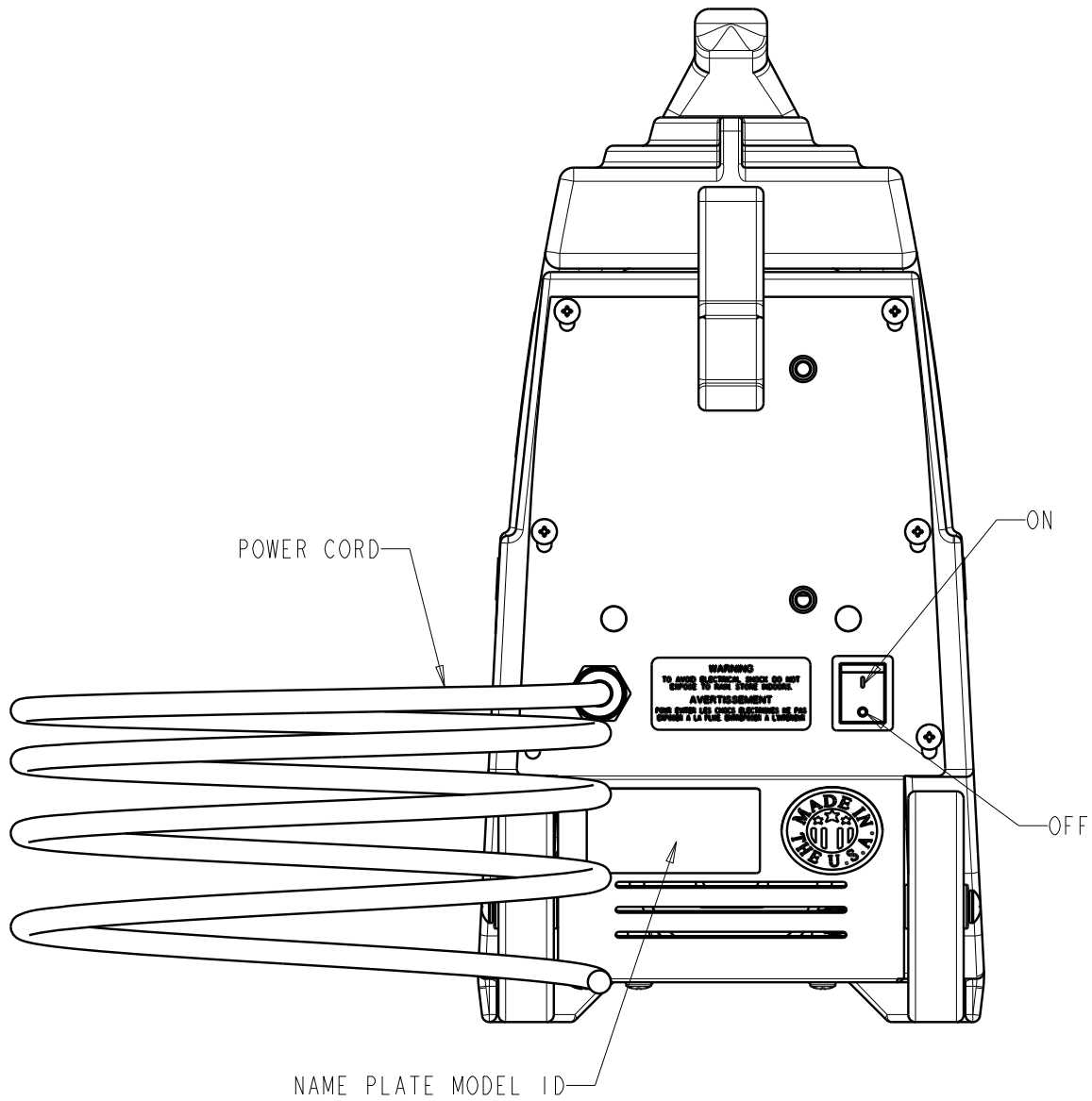

Frame Assembly (450200DS)

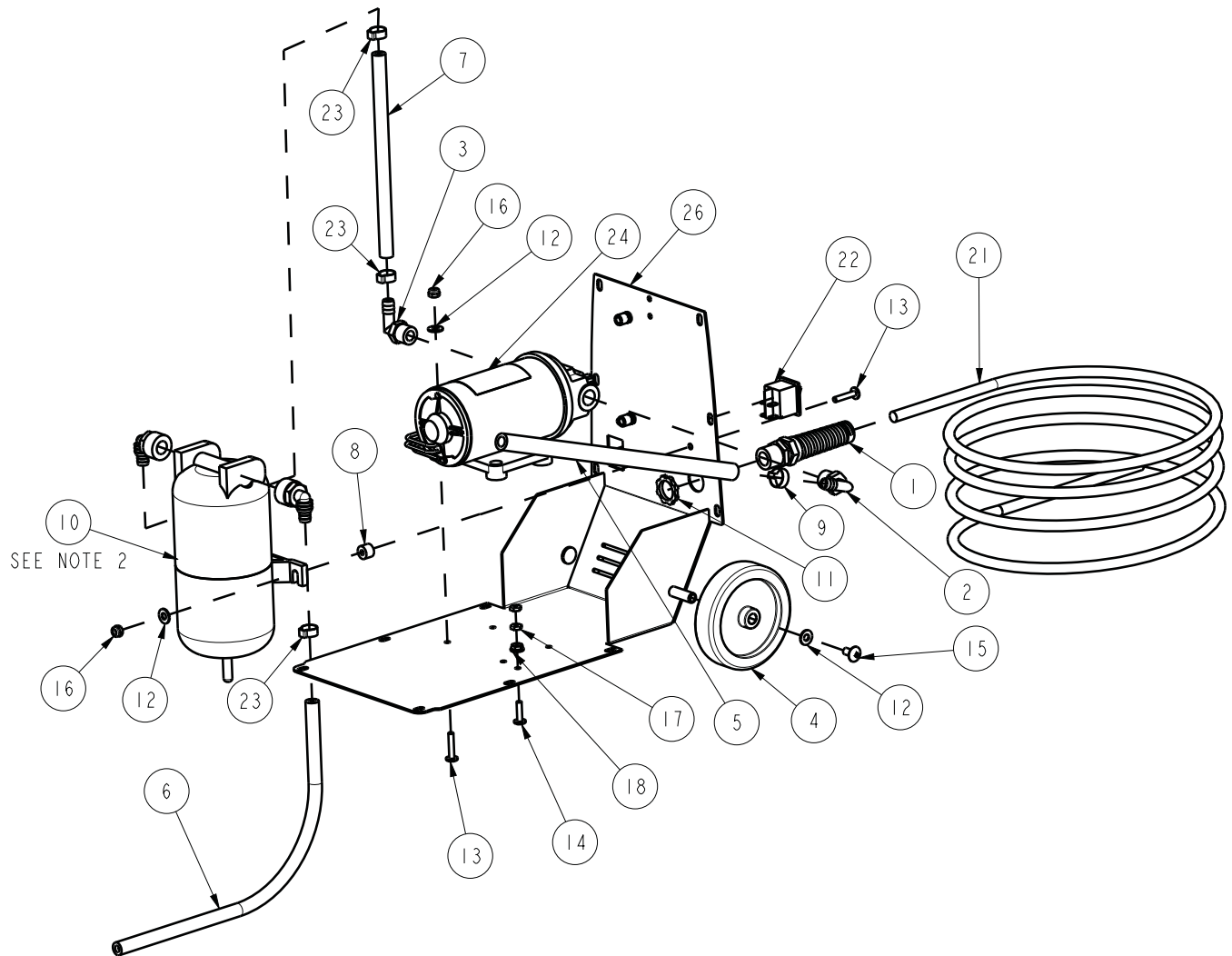

Frame Assembly BOM (450200DS)

Frame Parts List (450200DS)			
ITEM	PART #	QTY	DESCRIPTION
1	150004	1	STRAIN RELIEF, (PIGTAIL CORD GRIP)
2	450040	1	FTG-ELBOW 90 3/8 MPT X 3/8 HB NYLON
3	450222	1	FTG-ELBOW 90 3/8 MPT X 1/4 HB NYLON
4	450226	2	WHEEL-4"
5	450227	1	HOSE-WIRE REINF 3/8 X 12"
6	450303	1	HOSE-NYLO REINF 1/4 X 27
7	450304	1	HOSE-NYLO REINF 1/4 X 8"
8	450412	2	SPACER, .500 OD, .194 ID, .375 T
9	452037	1	CLAMP - 1 EAR .669 DIA 304SS
10	620277	1	ACCUMULATOR
11	711400	1	NUT-LOCK 1/2 ELECTRICAL NUT
12	711504	8	WASHER-FLAT 1/4 SS
13	712532	6	SCR-PHMS 10-24 X 1.00 SS
14	712537	1	SCR-THMS 10-24 X .75 SS
15	712560	2	SCR-THMS 1/4-20 X .50 SS W/NYLON PATCH
16	712638	6	NUT-NYLOC 10-24 SS
17	712905	2	NUT-HEX 10-24 SS
18	712908	1	NUT-FLANGED WIZZ 10-24 ZP
19	715009	1	DECAL-WARNING TO AVOID
20	715029	1	DECAL-NAME PLATE MODEL ID
21	740435	1	POWER CORD, 18/3 25 FT
22	748602	1	SWITCH, DPST ON-OFF IP55
23	450307	3	CLAMP, 1 EAR .453-.531 ID
24	829757-2HP	1	PUMP ASSY, 115V 100PSI
25	3334827	1	DECAL-MADE IN USA LEXAN, 1.75 DIA
26	450213DS-1	1	ASSY, WELD-FRAME, DS

Base Assembly

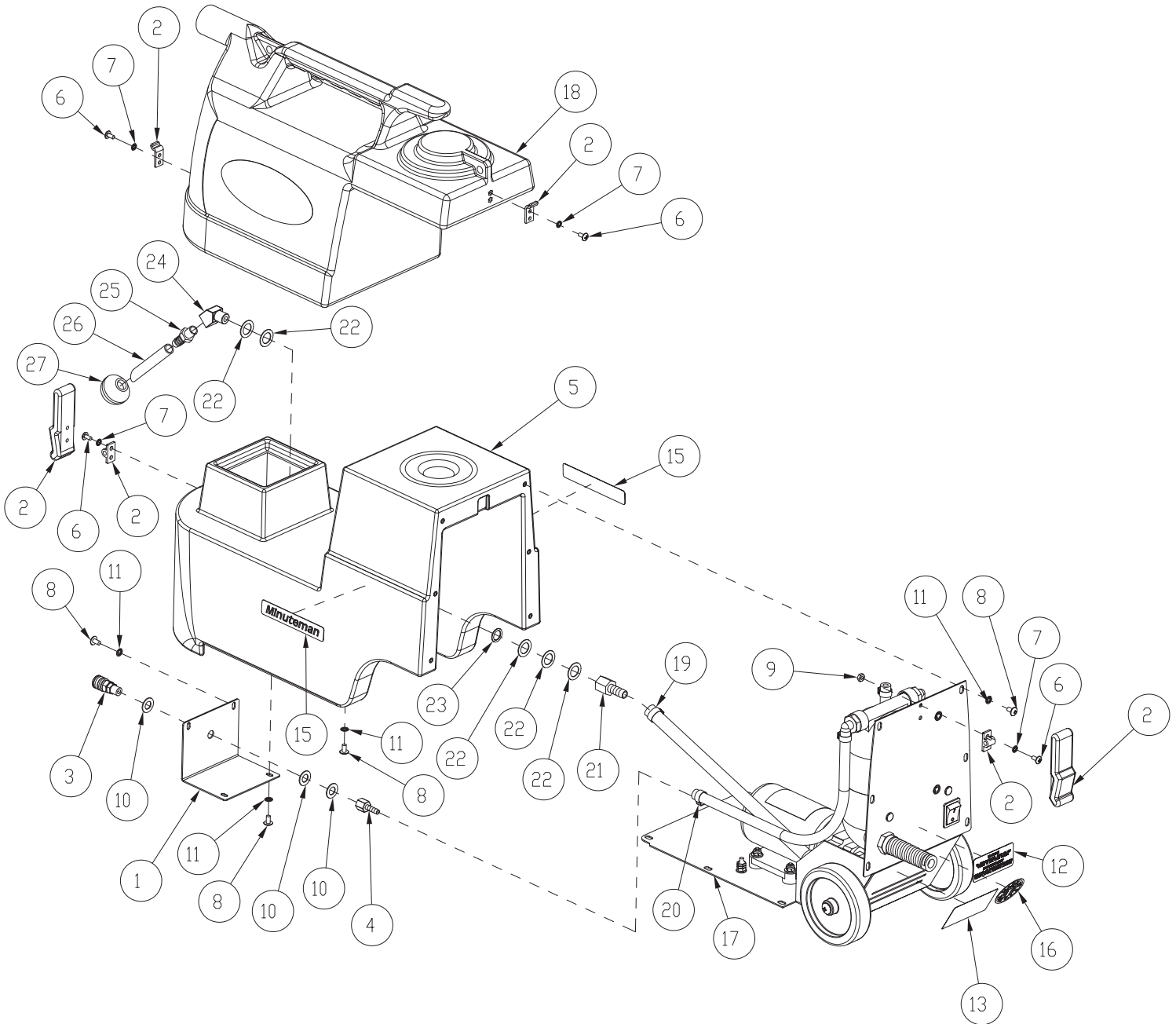

Base Assembly BOM

Base Parts List (450230-DS)			
ITEM	PART #	QTY	DESCRIPTION
1	450205	1	QUICK DISCNCT PLATE 16GA
2	450207	2	LATCH-SOFT
3	450221	1	COUPLER-QUICK CONNECT, 1/8MPT
4	450225	1	FTG-ADAPTER 1/8 FPT X 1/4 HB BRASS
5	450230-DS	1	SOLUTION TANK ASM, DISINFECT SPRAY
6	710025	8	SCR-THMS 8-32 X 3/8 SS
7	711552	8	WASHER-INT LOCK #8
8	712022	16	SCR-PHMS 10-24 X .37 ZP, SEM
9	712621	2	NUT-HEX 8-32 SS W/EXT TOOTH LOCKWASHER
10	712767	3	WASHER-FLAT .406 X .75 X .035 SS
12	715009	1	DECAL-WARNING TO AVOID
13	715029	1	DECAL-NAME PLATE MODEL ID
15	715380	2	DECAL-MMAN DG/LG .75 X 4.18
16	3334827	1	DECAL-MADE IN USA LEXAN, 1.75 DIA
17	450200DS	1	BASE PKG MIST IT 115V, DISINFECTANT SPRY
18	450201DS	1	TNK REC MIST IT LTGREY
19	452037	2	CLAMP - 1 EAR .669 DIA 304SS
21	833473	1	FTG-ADAPTER 1/4 FPT X 3/8 HB BRASS
22	711594	5	WASHER-FLAT .56 X .88 X .03 NICKEL
23	832326	1	O-RING, 1/2ID X 3/32
24	833906	1	FTG-ELBOW 45 1/4 MPT X 1/4 FPT BRASS
25	828952	1	FTG-ADAPTER 1/4 MPT X 3/8 HB PP
26	450216	1	SOLUTION HOSE
27	828974	1	STRAINER
26	450216	1	SOLUTION HOSE
27	828974	1	STRAINER

Handle Assembly (450413)

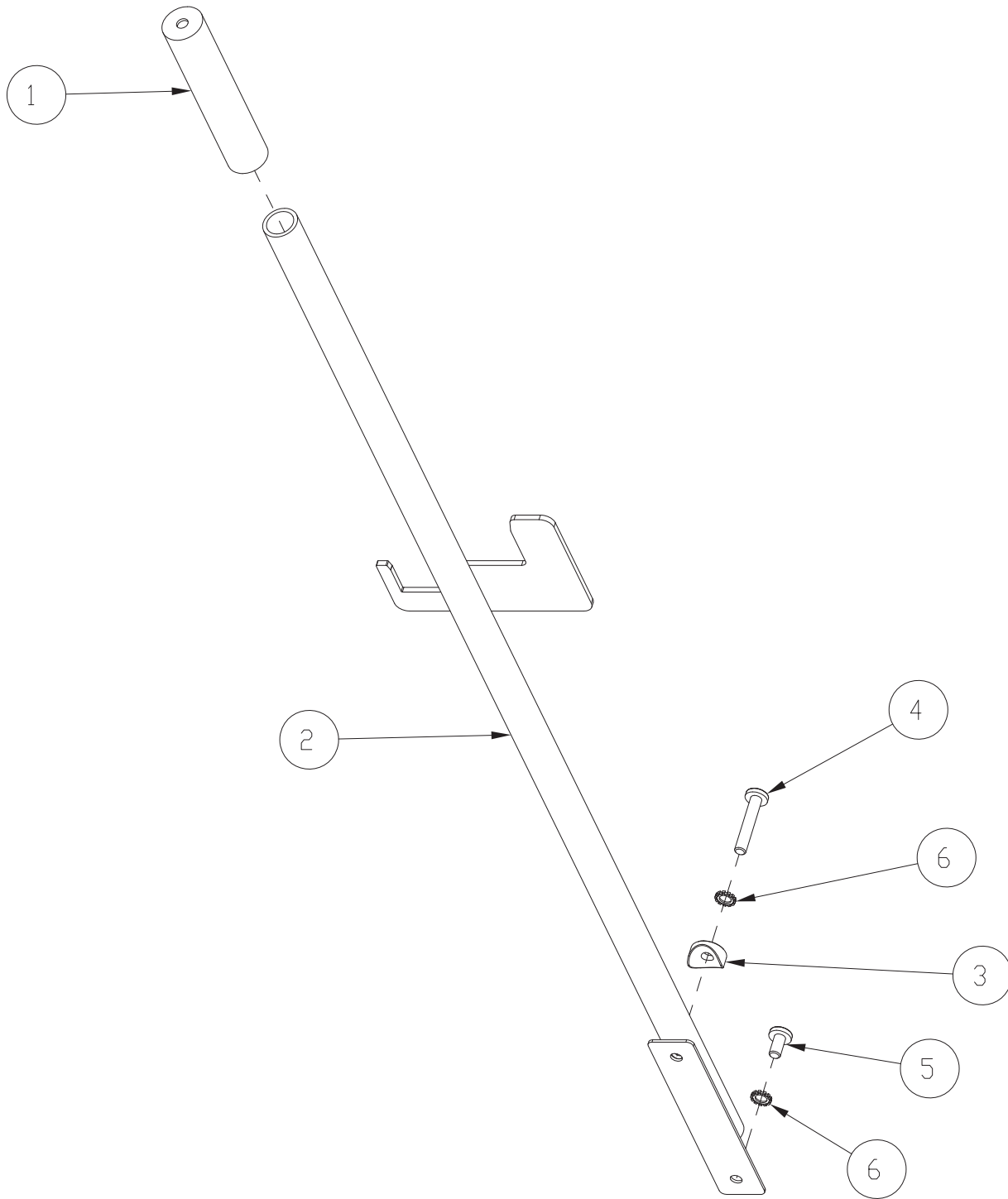

Handle Assembly BOM (450413)

Handle Parts List (450213)			
ITEM	PART #	QTY	DESCRIPTION
1	78-71-A	1	GRIP-HANDLE BLACK
2	450402	1	WELD-HANDLE
3	450404	1	SPACER, FOR .75 OD TUBE
4	450414	1	SCR-PHMS M6-1.00 X 35 ZP
5	11175239	1	SCR-PPHMS M6-1.0 X 12MM ZP
6	12518015	2	WASHER, SERRATED LOCK

Wand Assembly (450250DS)

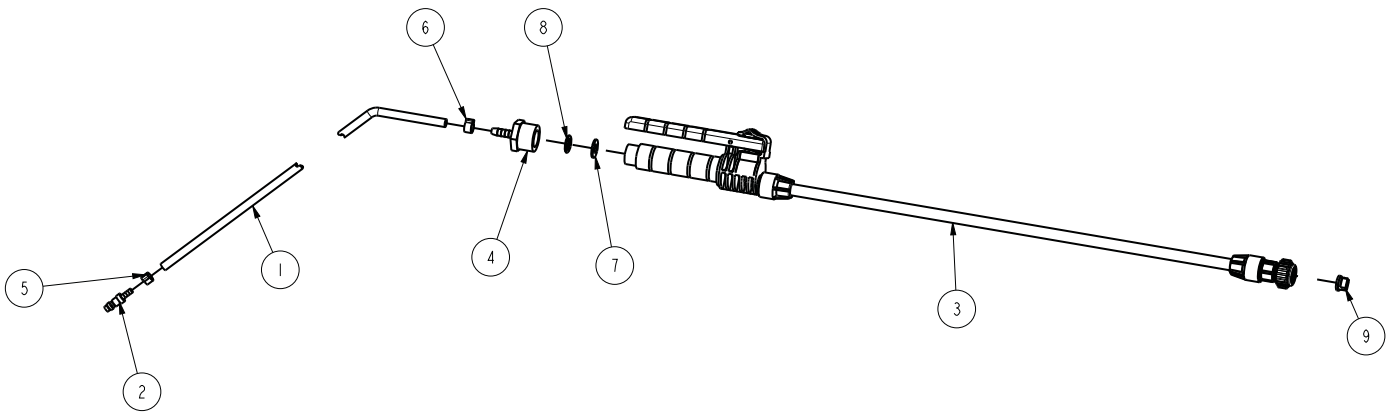

Wand Assembly BOM (450250DS)

Wand Parts List (450250DS)			
ITEM	PART #	QTY	DESCRIPTION
1	450208	1	SOLUTION HOSE, 25 FT
2	450279	1	FITTING-NIPPLE QUICK CONNECT 1/8 BARB
3	450305	1	WAND, DISINFECTANT SPRAYER
4	450306	1	FTG-ADAPTER 1/2 FPT X 1/4 HB
5	450308	1	CLAMP, 1 EAR .328-.390 ID
6	450309	1	CLAMP, 1 EAR .375-.438 ID
7	718420	1	WASHER, NEOPRENE, .359 ID x .734 OD
8	832326	1	O-RING, 1/2ID X 3/32
9	3339519	1	NOZZLE, SPRAY TIP 1100050

Option - Extension Wand (450311)

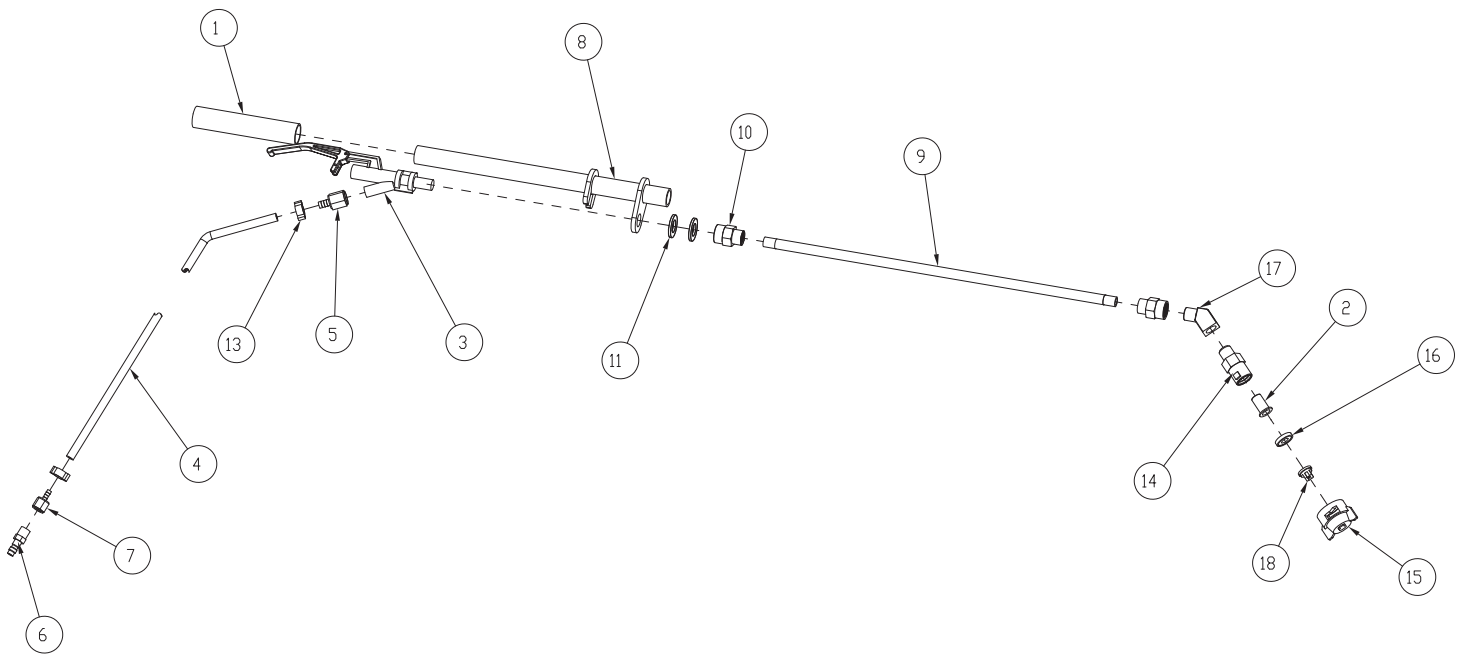

Option - Extension Wand BOM (450311)

Extension Wand Parts List (450311)			
ITEM	PART #	QTY	DESCRIPTION
1	78-71-A	1	GRIP-HANDLE BLACK
2	281041	1	VALVE-CHECK
3	390066	1	SOLUTION VALVE ASY COMP
4	450208	1	HOSE-1/8 ID NYLOBRAID RAW
5	450218	1	FTG-ADAPTER 1/4 FPT X 1/8 HB BRASS
6	450219	1	FITTING-NIPPLE QUICK CONNECT 1/8 MPT
7	450223	1	FTG-ADAPTER 1/8 FPT X 1/8 HB BRASS
8	450408	1	WELD-HANDLE, WAND
9	450409	1	PIPE, 1/8 NPT X 15" ALU
10	450410	2	FTG-COUPLING 1/4 FPT x 1/8 FPT BRASS
11	600950	2	WASHER-FLAT M12 ZP
13	830082	2	CLAMP - 2 EAR .433 DIA ELEC ZN
14	833140	1	CONNECTOR-BODY INLET
15	833141	1	CAP
16	833142	1	GASKET-CAP
17	833906	1	FTG-ELBOW 45 1/4 MPT X 1/4 FPT BRASS
18	3339519	1	NOZZLE, SPRAY TIP 1100050

Wiring

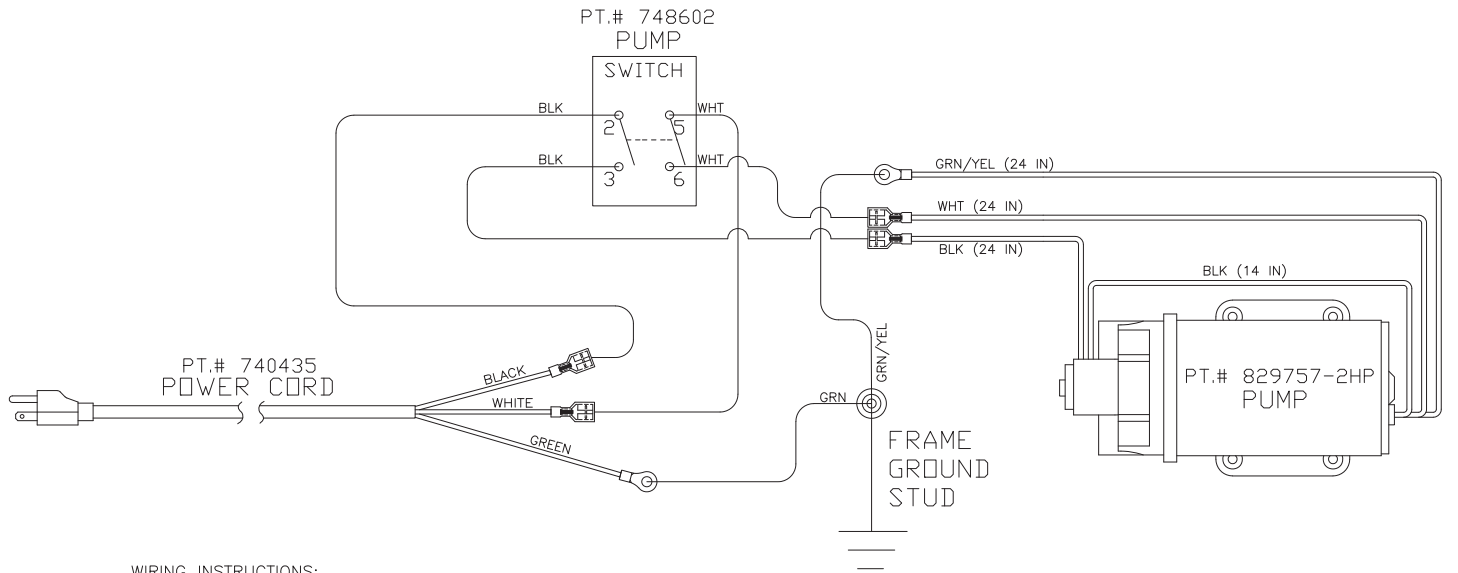

WIRING INSTRUCTIONS:

1. ATTACH BLACK WIRES TO SWITCH AS SHOWN.
2. ATTACH WHITE WIRES TO SWITCH AS SHOWN.
3. CONNECT GREEN & GREEN/YELLOW WIRES TO FRAME GROUND STUD.

NOTE:
ALL DIMENSIONS ARE SHOWN IN INCHES.

WIRE TOLERANCES	
0-1"	±1/16"
>1" - 12"	±1/4"
>12"	±1/2"

“Excellence Meets Clean”

**Minuteman is a Full Line Manufacturer of Sweepers and Scrubbers,
for Industrial Facilities.**